

Medical Rack AW169 – STC 10070355

Designed to support medical devices and Air/O2 cylinders essential for airborne medical assistance.

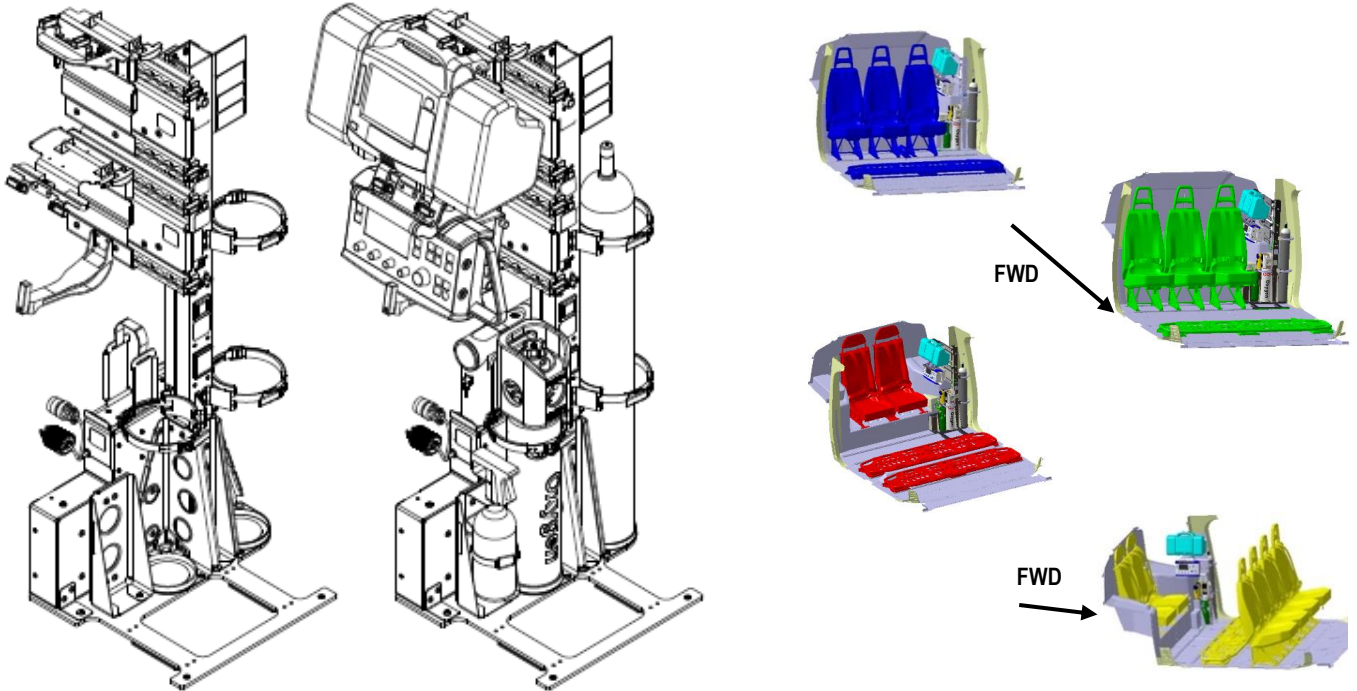

MEDICAL RACK	
<i>p/n</i>	TPS169-03-00
<i>Material</i>	AL2024
<i>Dimension LxWxH</i>	40.2 x 28.3 x122 cm
<i>Weight</i>	16.2kg

	COMPATIBLE DEVICES	DIMENSION AND WEIGHT
<i>Monitor / Defibrillator</i>	X series Zoll	29 x 18.4 x 17.5cm 6.0kg
<i>Ventilator</i>	Oxylog 3000 Draeger	29 x 18.4 x 17.5cm 5.8kg
<i>Suction Unit</i>	LCSU4 Laerdal	22 x 13 x 10.8cm 3kg
<i>Oxygen bottle</i>	BOC 101-CD BOC	L x D: 52 x 10cm 3.5kg
<i>Medical Air bottle</i>	BOC 191-E BOC	L x D: 29 x 10.6cm 6.5kg

Key Features

- CE Medical Certification & Production;
- Compliant with flammability Requirement;
- Accessory Box for Medical Devices and O₂/Air bottles;
- Rotate shelf for clear view of Medical Devices
- Quick and Easy Attach and Remove, compatible with standard attachment seat rails.
- Fire Extinguisher Support
- Integrated Electrical System

Electrical Characteristics

- N°1 220 VAC 60 Hz 550 VA Power Outlet;
- N°1 115 VAC 50 Hz 500 VA Power Outlet;
- N°2 USB sockets up to 2.4A;
- N°3 28 VDC Power Sockets to supply the medical devices;
- Max Power Consumption 500W.

Applicability on:

- AW169 RFM Supplement 40 "Stretcher installation" incorporated.
- Compatible with other configurations (STC to extended)